

## Exhaust Hood- 24" Wide



### Model # SS-324-E

### Product Specifications

#### HOOD DIMENSIONS

Outer Dimensions.: 24" D x 26" W x 25" H  
 Interior Dimensions: 23.5" D x 24" W x 24" H

#### HOOD MATERIAL

Sides: 0.250" White Acrylic  
 Base: 0.500" White High Density Polyethylene  
 Top: 0.500" Clear Polycarbonate  
 Front: 0.250" Clear Polycarbonate

#### EXHAUST CONNECTION

6" O.D. Outlet Collar. 4" Outlet Collar also available.  
 Ducting & Fan Not Included with this Product

#### WEIGHT

Approx. 45 lbs.

#### MAX. OPERATING TEMPERATURE

Not to exceed 170 degrees Fahrenheit

#### WARRANTY

Limited two-year warranty from date of shipment on defects due to materials or workmanship.  
 PATENT #5,843,197

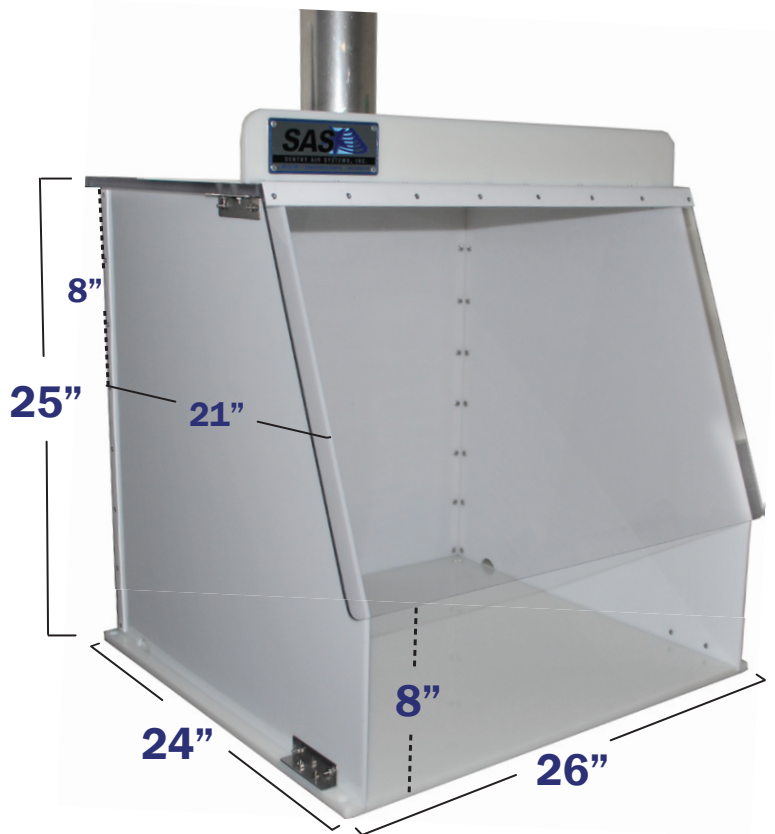

Shown with Outer Dimensions  
 Measurements are Approximate



### Product Features

- 30W Fluorescent Light Included
- Custom Sizes & Configurations Available
- Low Maintenance
- Sturdy Construction
- Other Standard Sizes: 18", 30", 40", 50", 60", 70"
- Attractive Appearance

Sentry Air's **24" Wide Ducted Exhaust Hood** may be an excellent choice for industrial applications that require a compact, exterior-ducting fume hood. This bench-top unit features unique hinged folding side panels, a high-density polyethylene base, a clear polycarbonate top, and a polycarbonate hinged sloping front lid. It is extremely compact and light weight. Typically, exhaust hoods may be used in chemical laboratories- especially those dealing with highly flammable, toxic, or corrosive chemicals, powder and capsule filling facilities, hazardous biological applications, nuclear testing facilities (with radioactive materials), and in a variety of other processes that require fume extraction.

The **24" Wide Ducted Exhaust Hood** can be an effective and economical tool for air quality enhancement in many commercial, chemical, medical, laboratory, and industrial applications.

This unit includes a 6" Outlet Collar and does not include ducting or fan. 4" Outlet Collar also available. For additional visibility, a transparent version is available at extra cost.



1-800-799-4609  
[www.sentryair.com](http://www.sentryair.com)  
[sales@sentryair.com](mailto:sales@sentryair.com)

